

SAS 421 / SAS 422 – SPEEDPICKER
AUTOMATION WITH LOADING AND UNLOADING STATION
ON ONE SIDE OF THE SYSTEM



SAS 421 / SAS 422 – *SpeedPicker*

**Automation with loading and unloading station
on one side of the system**





Integrated measurement technology



Slider system for vacuum transport



Contactless automation with the Bernoulli double gripper

TECHNICAL SPECIFICATIONS

SAS 421 / SAS 422 – SPEEDPICKER

Dimensions (L × W × H)	4,580 mm x 3,000 mm x 2,000 mm
Weight	5,000 kg

WORKING SPACE

Power supply	400 V / N / PE / 50 Hz
Compressed dry air	6-7 bar with 600 l/min
Connected load	13 kVA
Input lead	40 A
Control voltage	24 VDC
Accuracy	± 100 µm absolutely for wafer
Dimension wafer	156 mm x 156 mm (161 x 161) mm
Thickness wafer	≥ 120 µm
Breakage rate	< 0.05 % per robot
Throughput SAS 421 (single robot)	5,000 W/h with pallet 6 x 5
Throughput SAS 422 (double robot)	8,000 W/h with pallet 6 x 5 / 6 x 6 / 6 x 7 / 8 x 8
Technical uptime	approx. 98 %
Noise emission	approx. 72 dB in 1 m distance
Temperature range	22 °C – 26 °C with 40 % – 60 % relative humidity

FEATURES

- Gentle material handling
- Contactless gripping according to the Bernoulli principle
- Slider system for vacuum transport
- No impressions, thus better coating quality in downstream processes
- High throughput as a result of double gripper with up to 8,000 wafers per hour
- Minimum breakage rates of 0.05 %
- High-precision handling and positioning of wafers in the pallet with ± 100 µm tolerance
- Flexibility in case of pallet changes (software-based, without mechanical conversion)

AVAILABLE OPTIONS

- Color Inspection
- MES System
- RFID System
- Connection to IGV/AGV System
- CE-Execution
- UL-Execution

Execution as double side system available:
SAS 411 with single robot
SAS 412 with double robot

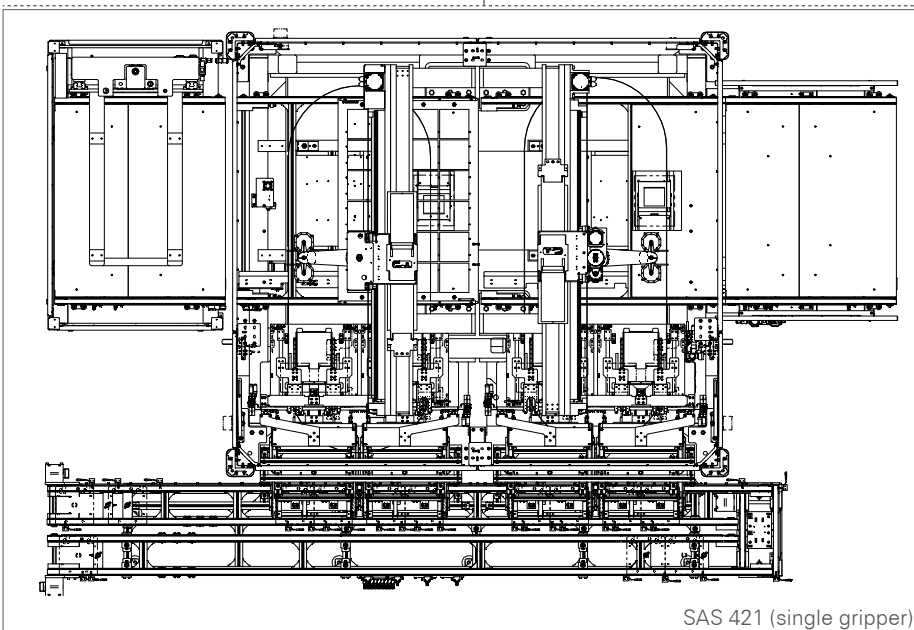

SAS 421 (single gripper)

Manz AG

Steigaeckerstrasse 5 • 72768 • Reutlingen • Germany
 Phone +49 7121 9000-0 • Fax +49 7121 9000-99 • info@manz.com